

FABRICS

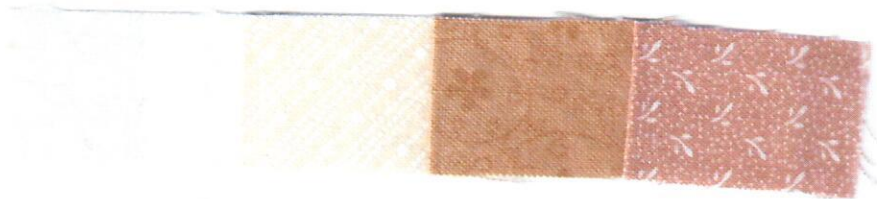
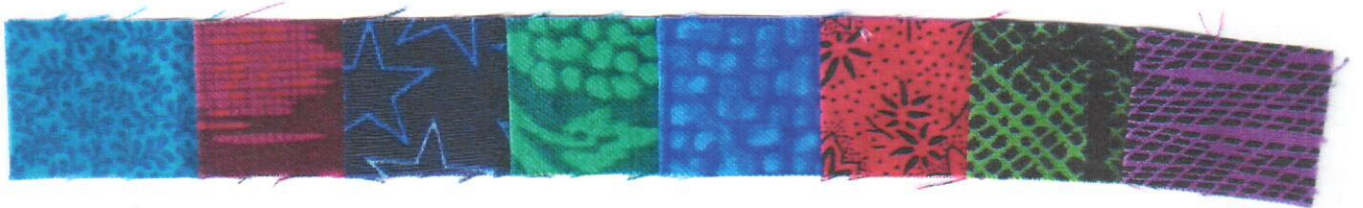

Bay Area Quilt Guild Scrap Exchange

General Instructions

1. Use only good quality 100% cotton fabric and thread. Pre-wash all fabric.
2. Seams must be an accurate $\frac{1}{4}$ " - please measure your own blocks in stages and the completed blocks before turning in.
3. If you choose to make more sets than the minimum required per instructions, each new set must be done in different fabrics. Label each additional pinned group as #2.
4. No duplicates in a pinned group unless stated in the instructions.
5. No IOUs.
6. Press blocks from the back first to make sure seam allowances are going the correct direction, then press the front to check for accuracy of points. Trim all threads and clip nubs. DO NOT trim block or square it up...as this cuts off points.
7. Pin blocks into groups according to the instructions and label each pinned group with your name and phone number. Place labeled pinned groups in a large baggie and label the outside with your name, phone number and the number of pinned groups traded. Remember one pinned group per person goes to the guild.
8. If you stitch blocks to trade together instead of pinning, please use ONLY 2 or 3 large basting stitches. DO NOT stick name labels to blocks, please use pins or basting stitch.

Terminology: SET - all blocks from the same fabric

PINNED GROUPS - one block from each SET for maximum variety - no repeats

STASH BUSTERS

BLOCK SIZE: 12" finished (12 1/2" unf.)
DUE DATE: TUESDAY, OCTOBER 31, 2023, Fabrics Etc box.
MEETING DATE: Tuesday, November 7, 6pm before guild meeting
CONTACT PERSON: Winnie Fleming 713-303-2795
NUMBER OF SETS: 3 different SETS of 10 blocks each
PINNED GROUPS TO TRADE: 10 PINNED GROUPS each consisting of 3 different blocks
FABRICS: Backgrounds; Muslin tone on tone AND Tan tone on tone. PRINTS: LIGHTS (NO WHITE BACKGROUND) and DARKS - prints or tone on tone with variety of texture and STRONG contrast between all fabrics. Ex: Lights should be same value, Darks should be same value etc.
FABRICS NOT TO USE: NO SOLIDS, avoid large multicolor prints that might not show strong contrast when next to another print or background

Strippy Stars

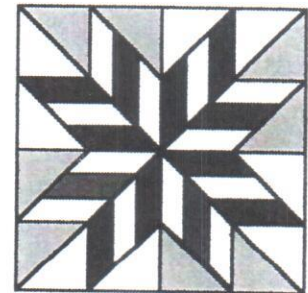

12" finished
(12 1/2" unf.)

When pulling fabrics, create 4 stacks, 1) LIGHT prints, 2) Dark prints, 3) Muslin tone on tones and 4) Tan tone on tones. All groups will touch the others so pull any fabrics that may be too close to one of the other groups. CONTRAST will create successful blocks.

Yardage needed for 1 SET (10 blocks): (repeat a total of 3 times. Prints may be occasionally repeated in other sets)

MUSLIN tone on tone: 1/2 yard

TAN tone on tone: 1/2 yard

LIGHT Prints - 12 different 1 1/2" cut strips (WOF)

DARK Prints - 12 different 1 1/2" cut strips (WOF)

Instructions for 1 SET (10 blocks). Repeat a total of 3 times for 30 blocks.

1. Cut the following for 10 blocks:

Backgrounds

TAN tone on tone - Cut 4 - $3 \frac{7}{8}$ " strips, subcut 40 - $3 \frac{7}{8}$ " squares, cut squares in half diagonally for a total of 80 triangles ☒

MUSLIN tone on tone - Cut 4 - $3 \frac{7}{8}$ " strips, subcut 40 - $3 \frac{7}{8}$ " squares, cut squares in half diagonally for a total of 80 triangles ☒

PRINTS (lights or darks may be repeated in other sets but no fabric repeated per set)

LIGHTS - Use 12 different fabrics and cut ONE $1 \frac{1}{2}$ " wide strip (WOF) from each. Do not cut selvages off. It's ok to use strips from fat quarters and sew end to end for one strip.

DARKS - Use 12 different fabrics and cut ONE $1 \frac{1}{2}$ " wide strip (WOF) from each. Do not cut selvages off. It's ok to use strips from fat quarters and sew end to end for one strip.

2. Make 4 different strip sets each with different LIGHT, DARK, LIGHT $1 \frac{1}{2}$ " strips. Begin with the bottom strip and stagger $1 \frac{1}{2}$ " down or to the right. PRESS toward the DARK strip. Each strip set should measure $3 \frac{1}{2}$ " wide.

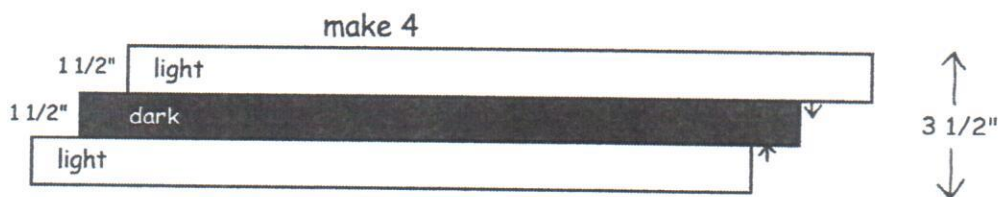

Next, Place the 45 degree line on a ruler over the middle seam and make an angled cut close to the selvages.

Then keep the 45 degree line over a middle seam with each cut and place the $2 \frac{5}{8}$ " line on ruler over the first cut. Cut 10 - $2 \frac{5}{8}$ " diamonds from each strip set for a total of 40 diamonds.

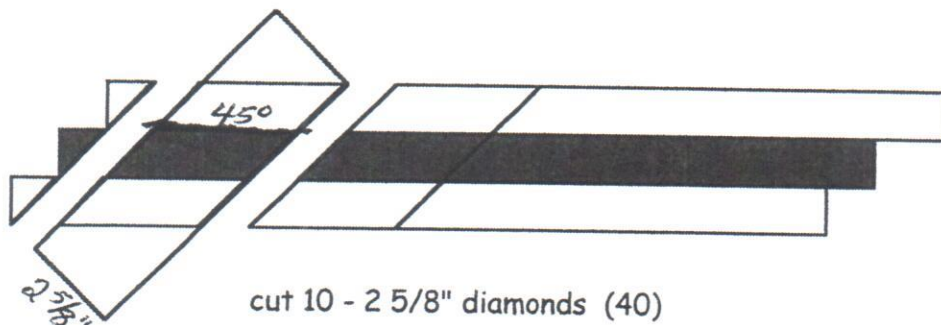

3. Make 4 different strip sets using DARK, LIGHT, DARK 1 1/2" strips. Begin with the bottom strip and stagger 1 1/2" up or to the left. PRESS toward the DARK strips. Each strip set should measure 3 1/2" wide.

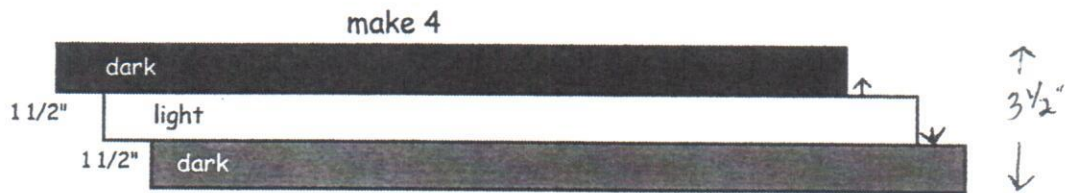

Next, place the 45 degree line on a ruler over the middle seam and make an angled cut close to the selvages. Then keep the 45 degree line over a middle seam with each cut and place the 2 5/8" line on ruler over the first cut. Cut 10 - 2 5/8" diamonds from each strip set for a total of 40 diamonds.

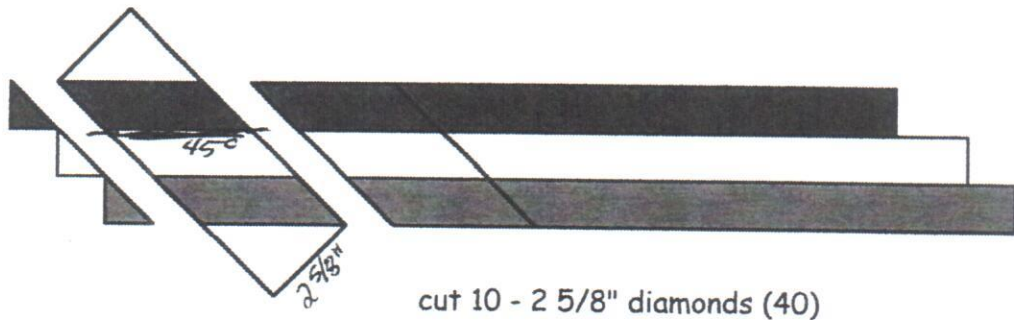

4. Next, with LIGHT, DARK, LIGHT diamonds, sew TAN 3 7/8" triangles according to numerical order of the drawing. Press the first seam toward the TAN before adding the second triangle.

Both seam should be pressed toward the TAN fabric. Press only the seam with the tip of the iron and avoid over-pressing the diamond. Clip excess tips for clean blocks.

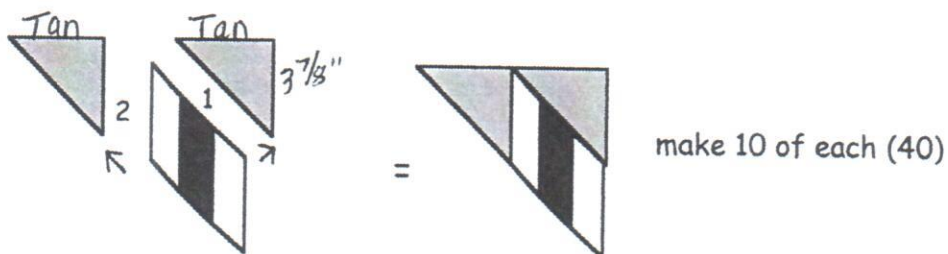

5. Use DARK, LIGHT, DARK diamonds and MUSLIN tone on tone $3\frac{7}{8}$ " triangles and sew triangles to diamonds according to the numerical order in the drawing. Press seams toward the DIAMOND before adding the next triangle. Press seam only and avoid over-pressing. Cut excess tips once sewn.

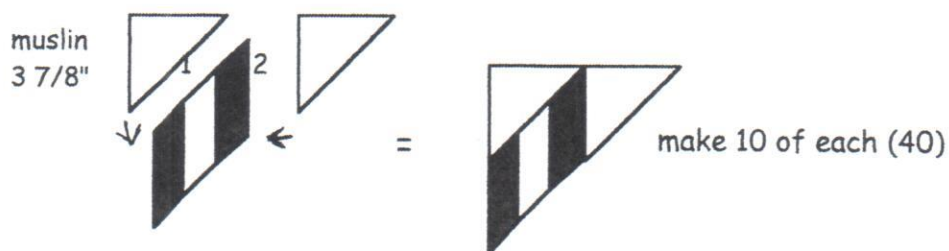

6. Next, sew pairs of MUSLIN and TAN pieced triangles together. All seams should be opposing for fine points. Press squares to the TAN block (press seam gently and avoid over-pressing).

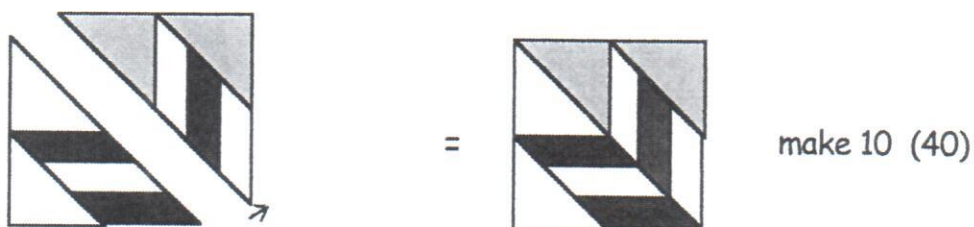

7. Sew final large blocks together by rows (similar to a 4-Patch). Press each seam toward the TAN, and then "spin" the center seam.

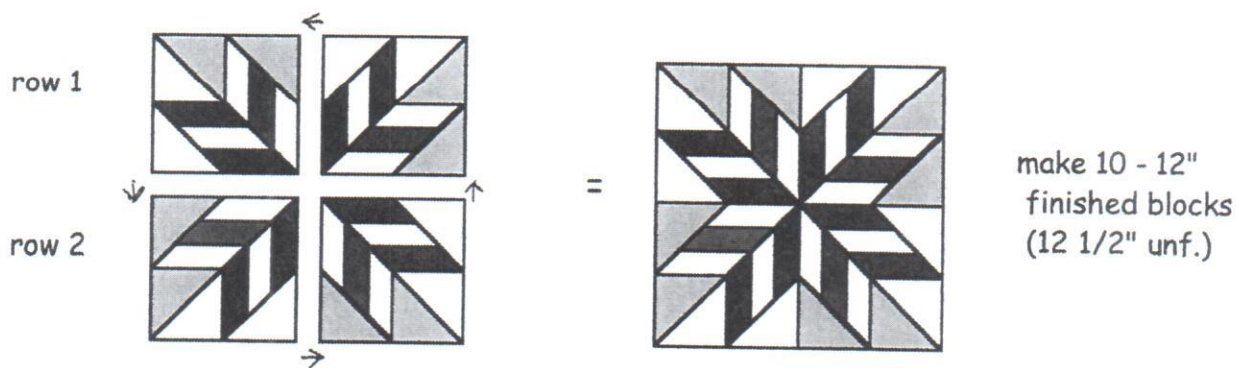

One Pinned Group: (3 different blocks)

