

# Bay Area Quilt Guild Scrap Exchange

## General Instructions

1. Use only good quality 100% cotton fabric and thread. Pre-wash all fabric.
2. Seams must be an accurate  $\frac{1}{4}$ " - please measure your own blocks in stages and the completed blocks before turning in.
3. If you choose to make more sets than the minimum required per instructions, each new set must be done in different fabrics. Label each additional pinned group as #2.
4. No duplicates in a pinned group unless stated in the instructions.
5. No IOUs.
6. Press blocks from the back first to make sure seam allowances are going the correct direction, then press the front to check for accuracy of points. Trim all threads and clip nubs. DO NOT trim block or square it up...as this cuts off points.
7. Pin blocks into groups according to the instructions and label each pinned group with your name and phone number. Place labeled pinned groups in a large baggie and label the outside with your name, phone number and the number of pinned groups traded. Remember one pinned group per person goes to the guild.
8. If you stitch blocks to trade together instead of pinning, please use ONLY 2 or 3 large basting stitches. DO NOT stick name labels to blocks, please use pins or basting stitch.

Terminology: SET - all blocks from the same fabric

PINNED GROUPS - one block from each SET for maximum variety - no repeats

## STASH BUSTERS

**BLOCK SIZE:** 10" finished ( 10 1/2" unf.)  
**DUE DATE:** TUESDAY, June 29, 2021 (Fabrics Etc box)  
**MEETING DATE:** TUESDAY, July 6 before Guild Meeting  
**CONTACT PERSON:** Winnie Fleming [winnief@juno.com](mailto:winnief@juno.com), 713-303-2795  
**NUMBER OF SETS:** 1 SET of 22 blocks  
**PINNED GROUPS TO TRADE:** 11 pinned groups each consisting of 2 blocks  
**FABRICS:** FALL COLORS - yellow, gold, orange, red, rust and light brown in a variety of different shades and texture, tone on tones. BACKGROUND - different light to medium BLUES tone on tones (no navy or dark blues).  
**FABRICS NOT TO USE:** NO Fabrics with a white or light background, No solids.

### FALL LEAVES

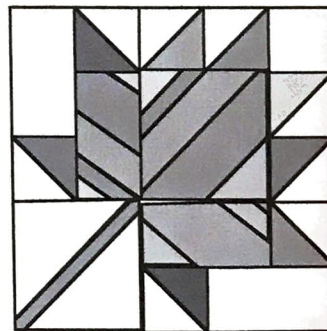

10" finished

*It's ok to repeat fabrics in a block in a different position but try to go as SCRAPPY as possible.*



## Instructions for ONE SET (22 blocks)

1. Half Square Triangles: Use 2" finished Half Square Triangles on a Roll, Thangles or Star Singles OR cut individual squares  $2\frac{7}{8}$ ".

Make 8 combinations of a FALL Fabric paired with a BLUE (fabrics may be repeated ONCE with a different combination). Make 22 - 2" finished HST of 8 combinations.

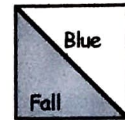

2" f. (2 1/2" unf.)  
make 8 sets of 22

Tips for Using HST Papers on a Roll: Pair Fall fabric and Blue,, right sides together, Pin layers with paper on top. Shorten stitch length and sew on the dashed diagonal lines, Cut on the solid lines. Remove papers and press toward the BLUE fabric. Clip tips for clean blocks.

2. FALL Fabric Strippy Squares and Rectangles:

Use a variety of different FALL fabrics and make 3 strip sets that measure approx 15" x 40" (selvage to selvage). For ONE strip set: Cut strips 3 - 1", 3 - 1 1/4", 3 - 1 1/2", 3 - 1 3/4" and 3 - 2". Fabrics may be repeated once in a strip set and place on opposite ends of the strip set. You can also use the same fabrics for all strip sets in different combinations.

Sew all 15 strips side by side (first sew pairs together, then join, etc) Once all strips are sewn together, press from the back first, then press from the front. You might want to spray the backside with light spray sizing or best press since bias edges will be on the outside.

Pieces to be cut from the 3 strip sets: 22 -  $4\frac{1}{2}$ " x  $4\frac{1}{2}$ ", 22 -  $2\frac{1}{2}$ " x  $4\frac{1}{2}$ " (staggered right), and 22 -  $2\frac{1}{2}$ " x  $4\frac{1}{2}$ " (staggered left).

To cut 22 -  $4\frac{1}{2}$ " x  $4\frac{1}{2}$ ", FIRST, place the 45 degree line on a long ruler over a middle seam and cut.

Then from that raw edge, cut 6 -  $4\frac{1}{2}$ " strips. Next, cut 4 -  $4\frac{1}{2}$ " squares from each strippy strip. (you might need to sew another small scrap to one end for the last square).

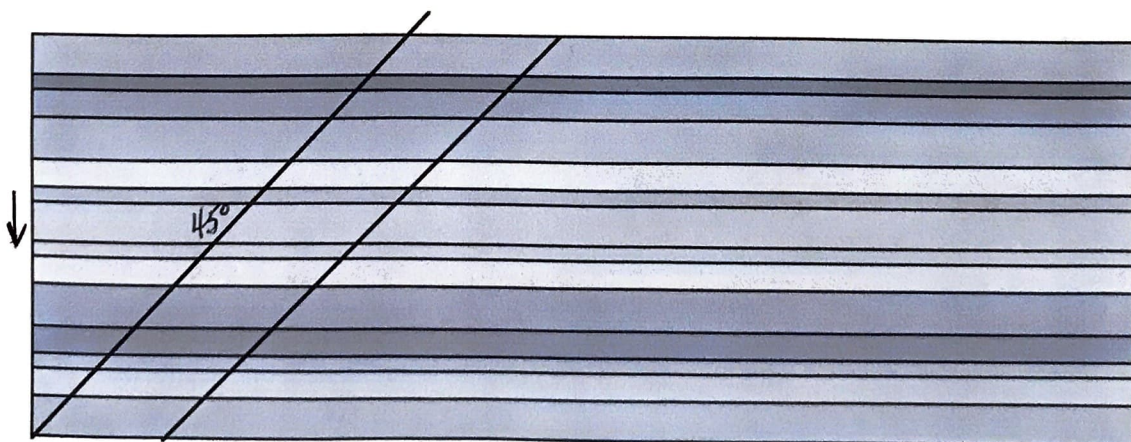

4 1/2"

2. Fall strippy squares cont:

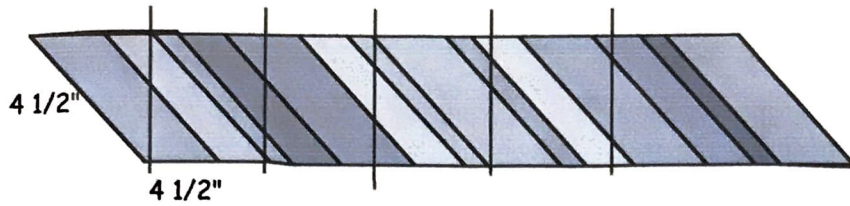

cut 22 - 4 1/2" x 4 1/2"

Repeat the same steps for the 22 - 2 1/2" x 4 1/2" (staggered right). Cut 4 - 4 1/2" strips, From each strippy strip, you can cut approx. 6 - 2 1/2" x 4 1/2" rectangles for a total of 22.

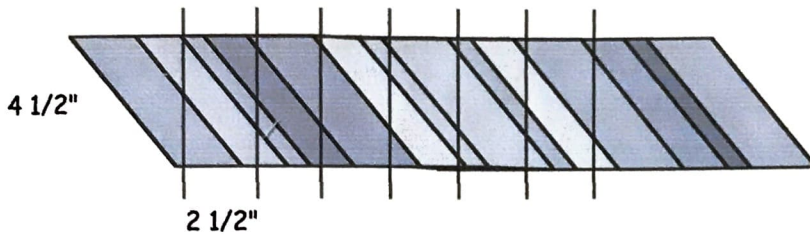

cut 22 - 2 1/2" x 4 1/2" (right)

To cut the 22 - 2 1/2" x 4 1/2" rectangles that are staggered from the left, place the 45 degree line on the ruler going the opposite direction, over a middle seam. Cut 4 - 4 1/2" strips, then subcut 22 - 2 1/2" x 4 1/2" rectangles.

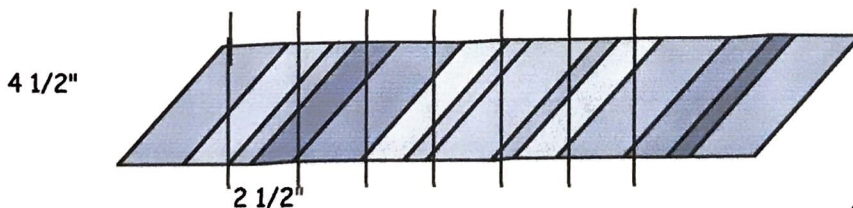
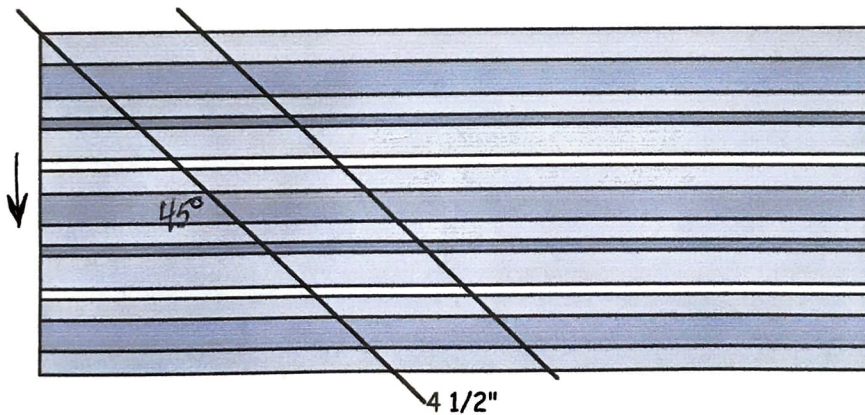

cut 22 - 2 1/2" x 4 1/2" (left)

\*\*\*Save leftover strippy pieces for a Bonus quilt or use for "Back Art"

### 3. Stem

Fall Fabric: Cut 4 - 3/4" strips (can be all the same or different)

Blue: Use at least 2 different fabrics and cut a total of 22 - 5" squares, Cut squares in half diagonally for a total of 44 triangles.

Next, sew the long side of the BLUE triangles to the FALL stem, then sew another BLUE triangle on the opposite side according to the diagram. Press toward the triangles. Next, use a 4 1/2" square ruler, center the diagonal line over the stem and cut out 22 - 4 1/2" x 4 1/2" squares.

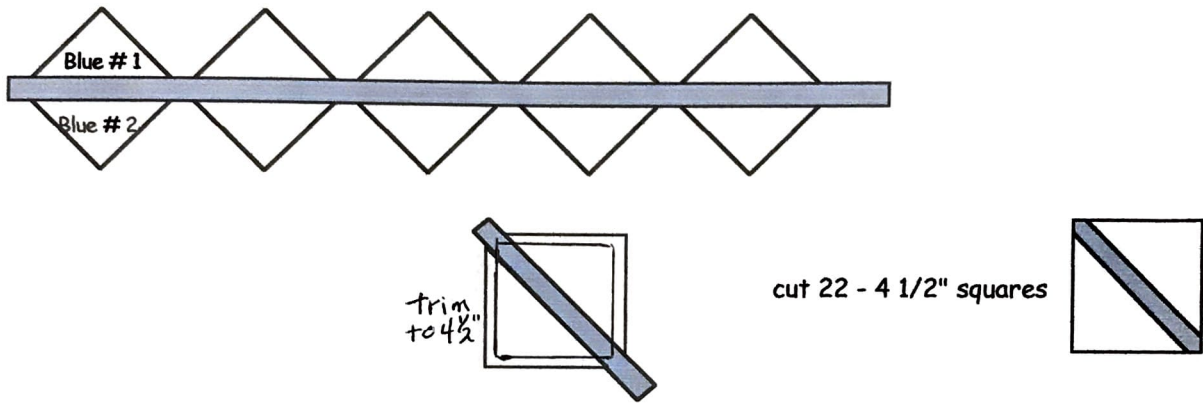

### 4. Blue Background Pieces: Cut the following

Cut 44 (at least 2 different fabrics) - 2 1/2" x 4 1/2" rectangles

Cut 22 - 2 1/2" squares

### 5. Piecing order:

Sew the block together by rows according to the diagram: Press bulky seams OPEN

